

## FP-4.0-T Pedal pump

- with fluid reservoir

The FP-4.0-T is a compact, pedal operated hydraulic pump with integrated fluid reservoir.

### Application

FP-4.0-T is designed to drive a single hydraulic cylinder, typically for height adjustment of working platforms, tables, beds or stretchers.

### Features

- ☑ Capacity 4 cc/stroke
- ☑ Pump and release function combined in pedal
- ☑ Throttled release flow to prevent sudden drop of load
- ☑ Spring centered pedal
- ☑ Maintenance free
- ☑ Easy to install
- ☑ Available with pedal fitted on left (V) or right (H) hand side.
- ☑ Customized pedal designs possible

### Installation

Installation is very simple: Fix the pump to the platform or the table frame by means of the four bolt holes in the pump base plate. Connect the cylinder to the fluid outlet/return port of the pump.

### Specifications

<b>Displacement</b>	<b>Fluid</b>
4 cc / stroke	Mineral/Synthetic oil
<b>Pressure</b>	<b>Weight</b>
max. 200 bar	4.2 kg
<b>Reservoir (std.)</b>	
0.35 L	

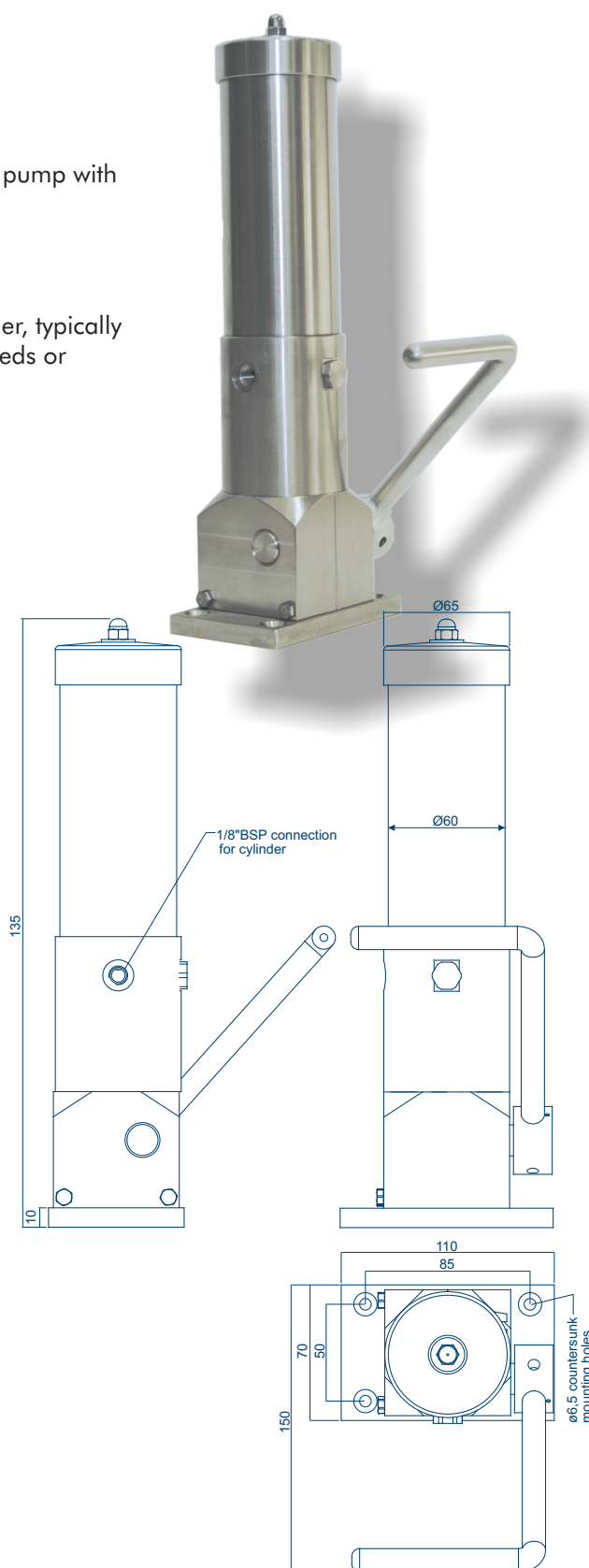

**SSH Stainless a-s**

Englandsvej 20-22 • 5700 Svendborg • Denmark  
 Tel: +45 6221 8531 • Fax: +45 6221 7840  
 Email: ssh@ssh-stainless.dk • www.ssh-stainless.dk

**Stainless  
 Steel  
 Hydraulics**