

SR20 Cylinder for oil hydraulics



Dimensions

SR20 is a double acting hydraulic cylinder made entirely of stainless steel. Standard piston diameters from $\varnothing 25$ mm through to $\varnothing 100$ mm.

Application

Typically used within food industry, fishing industry and environmental technology. The cylinder design is simple and robust ensuring long service life in adversely affected environments.

Cylinder Tube

Seamless stainless steel tube, quality W.St. 1.4301, Ra max. 0.3 micron. Internal tolerance H9. The cylinder tube is also available in acid proof material W.St. 1.4401.

Piston Rod

Centerless-polished stainless steel, quality W.St. 1.4301 hard chromed min. 20 μm . (1.4460 optional) Ra max. 0.3 μm . External tolerance h9

Piston Rod Speed

Max. speed 0.3 m/s. For higher velocities special seals are required. Please state when ordering.

Seals

Piston Compact packing with nitrile centre ring, polyelastomer shock rings and acetal wear rings

Piston rod Acrylic nitrile rubber seal ring

Wear Rings PTFE-carbon compound

Scraper PTFE-carbon, single lip

Connections

Cylindrical pipe thread BSP

Operation pressure

Max. 200 bar.

Operation temperature

Temperature range: -20° to $+100^{\circ}$ C

Pressure fluid

Hydraulic oil on mineral oil basis

Test

Pressure tested to 250 bar.



Dimensioner

SR20 er en dobbeltvirkende hydraulik-cylinder fremstillet i rustfrit stål. Standard stempeldiameter fra $\varnothing 25$ mm til og med $\varnothing 100$ mm.

Anvendelse

Anvendes typisk indenfor levnedsmiddel-industri, fiskeri/maritimt og miljøteknik. Cylinderne er af enkel og robust konstruktion, der sikrer lang levetid i belastede miljøer.

Cylinderrør

Sømløst rustfrit stålrør, kvalitet W.St. 1.4301, Ra max. 0,3 mikron. Indvendig tolerance H9. Cylinderrøret leveres også i syrefast materiale W.St. 1.4401

Stempelstang

Centerless-slebet rustfrit stål, kvalitet W.St. 1.4301, (1.4460 på forespørgsel) hårdforkromet min. 20 μm . Ra max. 0,3 μm . Udvendig tolerance h9.

Stempelstangshastighed

Max. hastighed 0,3 m/s. Ved højere hastighed anvendes specialpakninger. Venligst oplys ved ordre.

Pakninger

Stempelpakning Kompakttætning med nitrilring, stødringe i polyelastomer og føringsringe i acetalplast

Stempelstang Tekstil-indvævet acrylnitril

Føringsbånd PTFE med kulfyld

Afstryger PTFE med kulfyld, enkeltlæbe

Tilslutninger

Cylindrisk rørgvind BSP

Driftstryk

Max. 200 bar

Driftstemperatur

Temperaturområde: -20° til $+100^{\circ}$ C

Trykmedie

Hydraulikolie på mineraloliebasis

Test

Tryktestet til 250 bar

SR20 Cylinder for oil hydraulics



Position Sensing Equipment

Magnetic Field Sensor

System based on internal, piston fitted magnets and external sensors.

For further information see page 4.1 or enter our homepage:
www.ssh-stainless.dk/ *Magnetic Field Sensor*

Integrated Sensors

Built-in, contactless positioning sensor. Analogue or digital output signal.

For further information see page 5.1 or enter our homepage:
www.ssh-stainless.dk/ *Special Cylinders*



Positioneringsudstyr

Magnetfelt sensor

Systemet er baseret på indvendigt stempel monterede magneter og udvendige sensorer.

For yderligere information se side 4.1 eller besøg vores hjemmeside:
www.ssh-stainless.dk/ *Magnetic Field Sensor*

Indbygget positionsføler

Berørings-løs positionsføler med enten analogt eller digitalt signal.

For yderligere informationer se side 5.1 eller besøg vores hjemmeside:
www.ssh-stainless.dk/ *Special Cylinders*

Standard ends for cylinder and piston rod

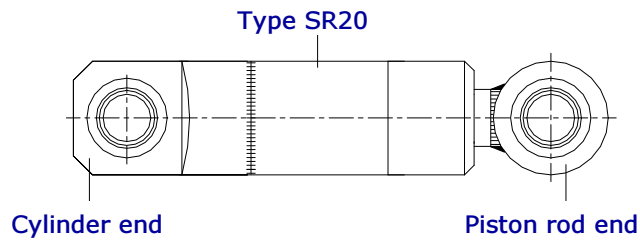

The ends and bearings for the cylinder and piston rod may be combined according to requirements.

If the chosen combination is not to be found under the shown cylinder types, you can either combine the shown ends for cylinders or contact us for further information.



De illustrerede cylinder og stempelstangs ophæng kan frit kombineres i henhold til ønske.

Hvis den ønskede kombination ikke findes under de viste cylindertyper, kan man enten kombinere de viste cylinderophæng eller kontakte os for yderligere information.

Cylinder ends

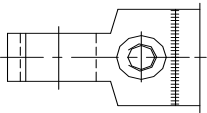
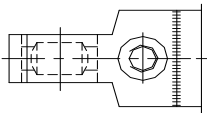
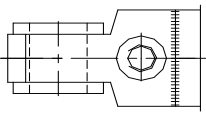
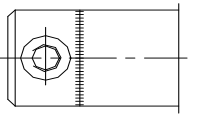
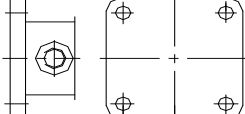
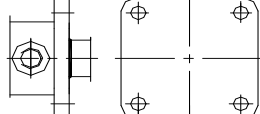
<p>V: Standard eye</p>  <p>V: Fast øje</p>	<p>L: Spherical bearing</p>  <p>L: Sfærisk ledleje</p>	<p>N: Nylon bushing</p>  <p>N: Nylon bøsning</p>
<p>O: Flat end</p>  <p>O: Glat ende</p>	<p>F: Bottom flange</p>  <p>F: Bundflange</p>	<p>H: Front flange</p>  <p>H: Frontflange</p>

Piston rod ends

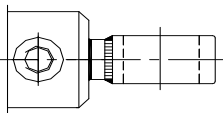
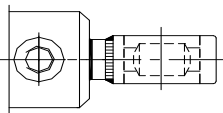
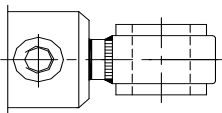
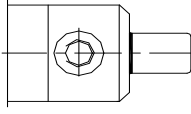
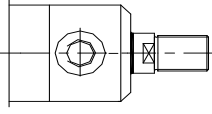
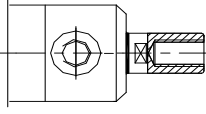
<p>Z: Standard eye</p>  <p>Z: Fast øje</p>	<p>L: Spherical bearing</p>  <p>L: Sfærisk ledleje</p>	<p>N: Nylon bushing</p>  <p>N: Nylon bøsning</p>
<p>O: Flat end</p>  <p>O: Glat ende</p>	<p>D: External thread</p>  <p>D: Udvendt gevind</p>	<p>P: Internal thread</p>  <p>P: Indvendigt gevind</p>

SR20 VZ cylinders

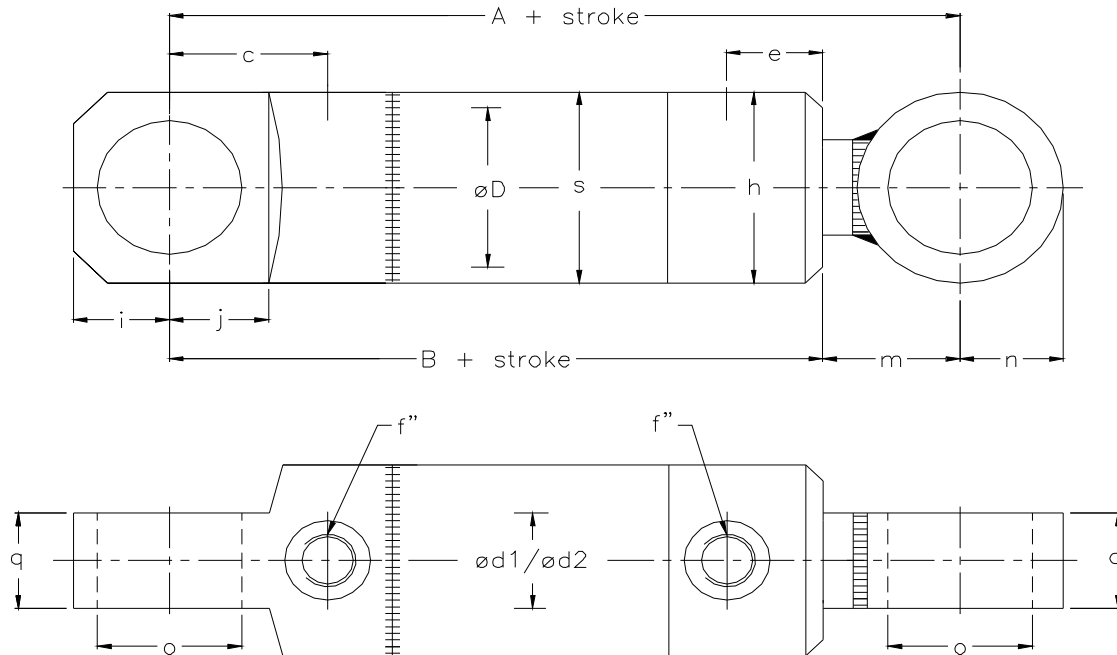

Dimension table

$\varnothing D$	25	32	40	50	63	80
$\varnothing d1/\varnothing d2$	12/16	16	20/25	25/30	30/40	40/50
A	135	155	185	217	225	265
B	95	126	150	177	180	213
c	20	24	36	46	38	50
e	26	24	25	28	28	39
f''	1/8"	1/4"	1/4"	3/8"	3/8"	1/2"
h	40	50	50/55	60	75	100
i	12	18	25	28	35	40
j	13	18	23	29	35	38
m	40	29	35	40	45	52
n	14	19	25	30	35	45
o	15	26	35	42	47	62
q	15	20	25	30	35	45
s	30	40	50	60	75	95

How to order:



SR20 VZ x1 / x2 * x3 K

x1: Inside diameter : 50 mm
 x2: Piston rod : 30 mm
 x3: Stroke : 200 mm

Ordering code: SR20 VZ 50/30*200 K

Eksempel på ordre:



SR20 VZ x1 / x2 * x3 K

x1: Indvendig diameter : 50 mm
 x2: Stempelstang : 30 mm
 x3: Slaglængde : 200 mm

Ordre kode: SR20 VZ 50/30*200 K

SR20 LL cylinders

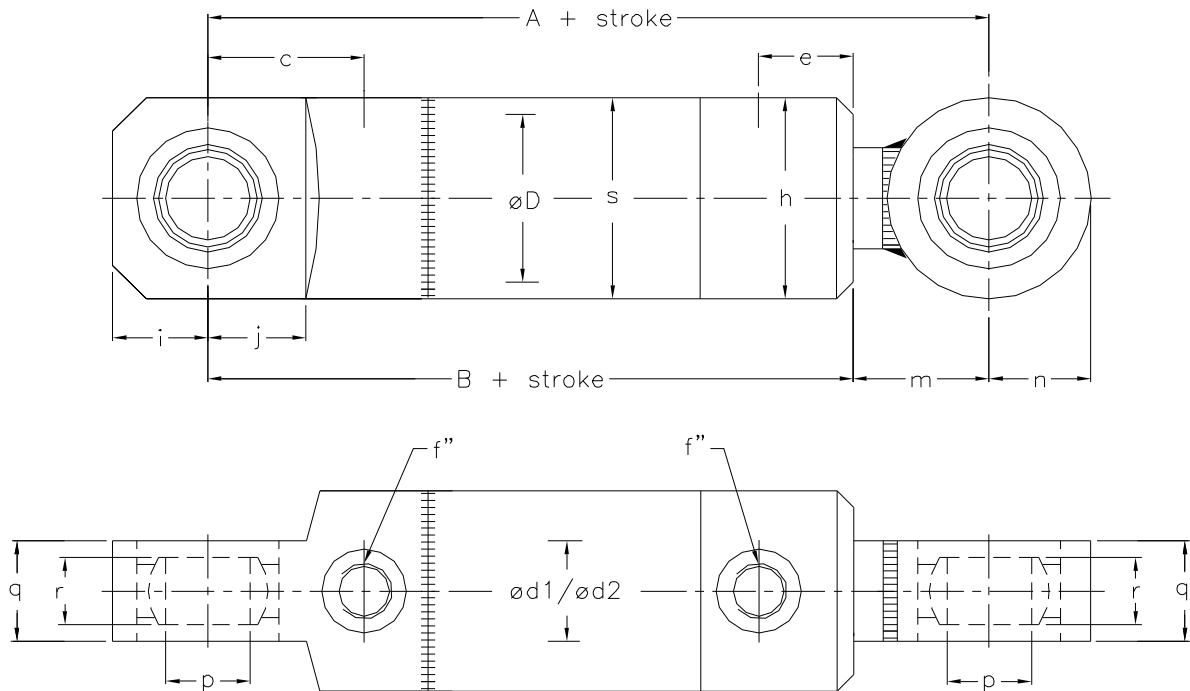

Dimension table

øD	32	40	50	63	80
ød1/ød2	16	20/25	25/30	30/40	40/50
A	155	185	217	225	265
B	126	150	177	180	213
c	24	36	46	38	50
e	24	25	28	28	39
f''	1/4"	1/4"	3/8"	3/8"	1/2"
h	50	50/55	60	75	100
i	18	25	28	35	40
j	18	23	28	35	38
m	29	35	40	45	52
n	19	25	30	35	45
p	15	20	25	30	40
q	20	25	30	35	45
r	15	16	20	22	35
s	40	50	60	75	95

How to order:



SR20 LL x1 / x2 * x3 K

x1: Inside diameter : 50 mm
 x2: Piston rod : 30 mm
 x3: Stroke : 200 mm

Ordering code: SR20 LL 50/30*200 K

Eksempel på ordre:



SR20 LL x1 / x2 * x3 K

x1: Indvendig diameter : 50 mm
 x2: Stempelstang : 30 mm
 x3: Slaglængde : 200 mm

Ordre kode: SR20 LL 50/30*200 K

SR20 NN cylinders

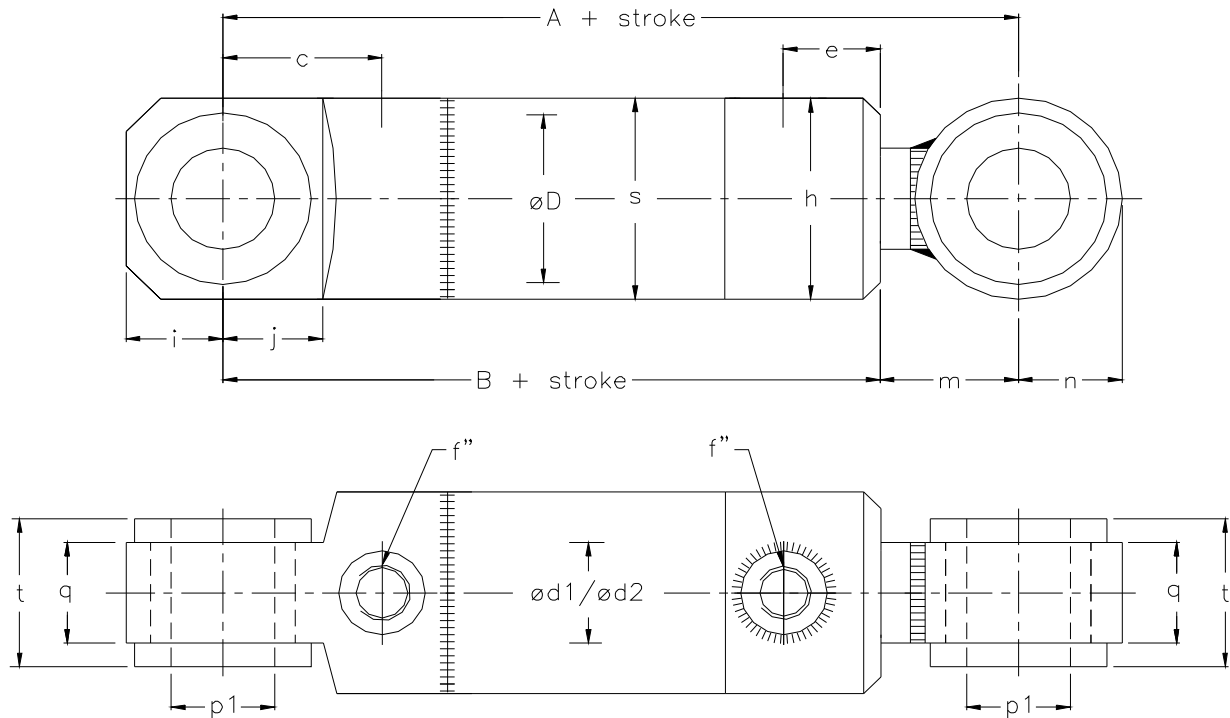

Dimension

øD	25	32	40	50	63	80
ød1/ød2	12/16	16	20/25	25/30	30/40	40/50
A	135	155	185	217	225	265
B	104	126	150	177	180	213
c	20	24	36	46	38	50
e	26	24	25	28	28	39
f''	1/8"	1/4"	1/4"	3/8"	3/8"	1/2"
h	38	45	50	60	75	100
i	12	18	25	28	35	40
j	12	18	23	28	35	38
m	31	29	35	40	45	52
n	13	19	25	30	35	45
p1	10	15	20	30	30	35
q	15	20	25	30	35	45
s	30	40	50	60	75	95
t	15	20	35	44	50	60

How to order:



SR20 NN x1 / x2 * x3 K

x1: Inside diameter : 50 mm
x2: Piston rod : 30 mm
x3: Stroke : 200 mm

Ordering code: **SR20 NN 50/30*200**

Eksempel på ordre:



SR20 NN x1 / x2 * x3 K

x1: Indvendig diameter : 50 mm
x2: Stempelstang : 30 mm
x3: Slaglængde : 200 mm

Ordre kode: **SR20 NN 50/30*200 K**

SR20 HD and HP cylinders

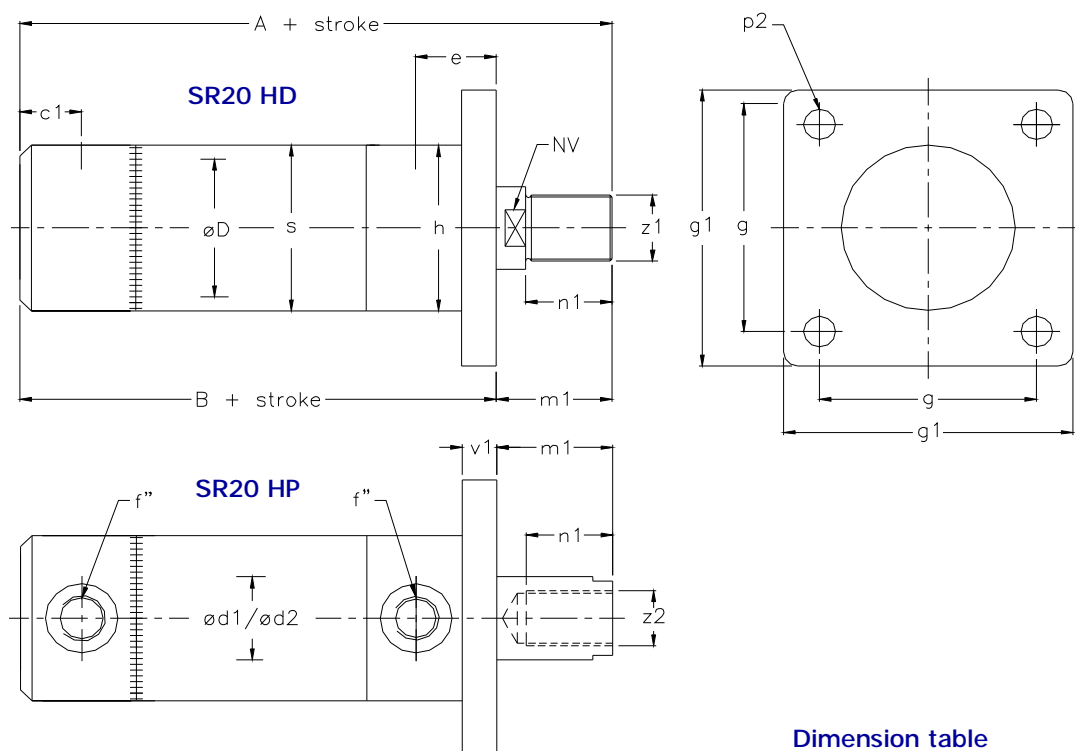

Dimension table

øD	25	32	40	50	63	80
ød1/ød2	12/16	16	20/25	25/30	30/40	40/50
A	119	147	163	193	209	249
B	88	118	128	153	164	189
c1	13	16	17	21	22	26
e	26	24	25	28	28	39
f''	1/8 "	1/4 "	1/4 "	3/8 "	3/8 "	1/2 "
g	50	50	65	75	85	110
g1	70	70	90	100	120	140
h	40	50	50/55	60	75	100
m1	31	29	35	40	45	60
n1	24	22	25	30	35	40
NV	10/13	13	17/22	22/27	27/36	36/42
p2	9	9	11	11	14	14
s	30	40	50	60	75	95
z1	M10x1,50 M12x1,75	M12x1,75	M16x2,00 M22x2,00	M22x2,00 M24x1,50	M24x1,50 M36x2,00	M36x2,00 M36x2,00
z2	M8x1,25	M8x1,25	M12x1,75 M16x2,00	M16x2,00 M20x2,50	M20x2,50 M24x2,00	M24x2,00 M24x2,00
v1	8	9	9	11	15	18

How to order:



SR20 HD x1 / x2 * x3 K

x1: Inside diameter : 50 mm
 x2: Piston rod : 30 mm
 x3: Stroke : 200 mm

Ordering code: SR20 HD 50/30*200 K

Eksempel på ordre:



SR20 HD x1 / x2 * x3 K

x1: Indvendig diameter : 50 mm
 x2: Stempelstang : 30 mm
 x3: Slaglængde : 200 mm

Ordre kode: SR20 HD 50/30*200 K

SR20 FD and FP cylinders

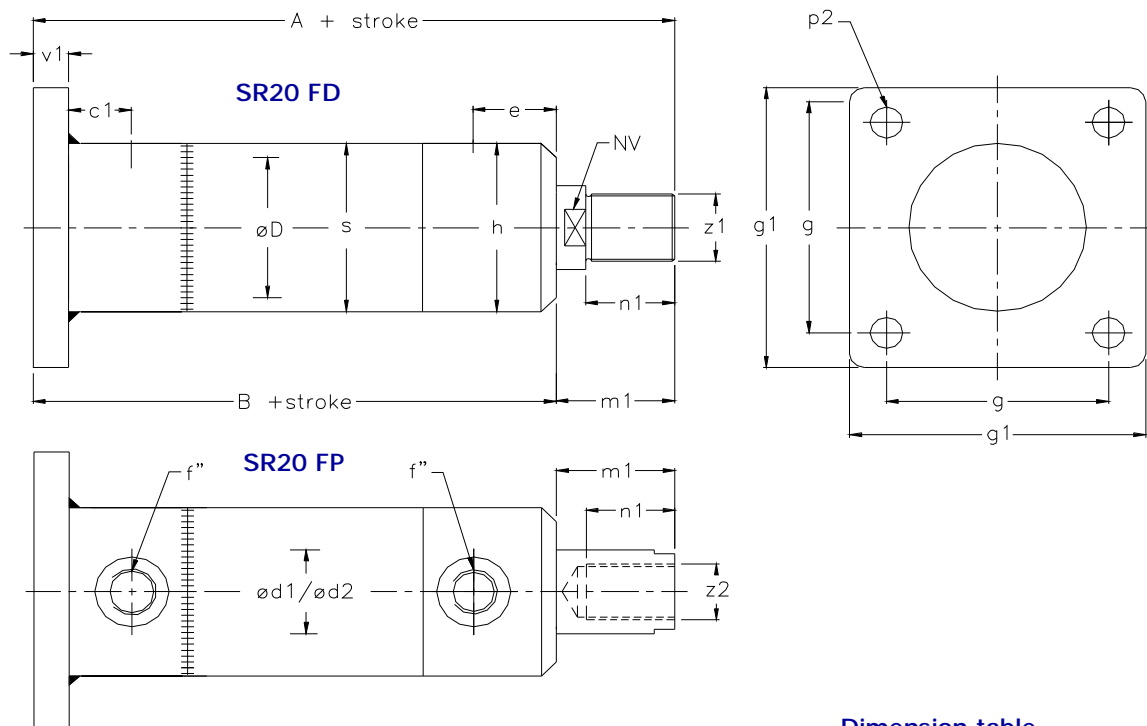

Dimension table

øD	25	32	40	50	63	80
ød1/ød2	12/16	16	20/25	25/30	30/40	40/50
A	127	156	172	204	224	267
B	96	127	137	164	179	207
c1	13	16	17	21	22	26
e	26	24	25	28	28	39
f''	1/8 "	1/4 "	1/4 "	3/8 "	3/8 "	1/2 "
g	50	50	65	75	85	110
g1	70	70	90	100	120	140
h	40	50	50/55	60	75	100
m1	31	29	35	40	45	60
n1	24	22	25	30	35	40
NV	10/13	13	17/22	22/27	27/36	36/46
p2	9	9	11	11	14	14
s	30	40	50	60	75	95
z1	M10x1,50 M12x1,75	M12x1,75	M16x2,00 M22x2,00	M22x2,00 M24x1,50	M24x1,50 M36x2,00	M36x2,00 M36x2,00
z2	M8x1,25	M8x1,25	M12x1,75 M16x2,00	M16x2,00 M20x2,50	M20x2,50 M24x2,00	M24x2,00 M24x2,00
v1	8	9	9	11	15	18

How to order:



SR20 FD x1 / x2 * x3 K

x1: Inside diameter : 50 mm
 x2: Piston rod : 30 mm
 x3: Stroke : 200 mm

Ordering code: SR20 FD 50/30*200 K

Eksempel på ordre:



SR20 FD x1 / x2 * x3 K

x1: Indvendig diameter : 50 mm
 x2: Stempelstang : 30 mm
 x3: Slaglængde : 200 mm

Ordre kode: SR20 FD 50/30*200 K

SR20 VD cylinders

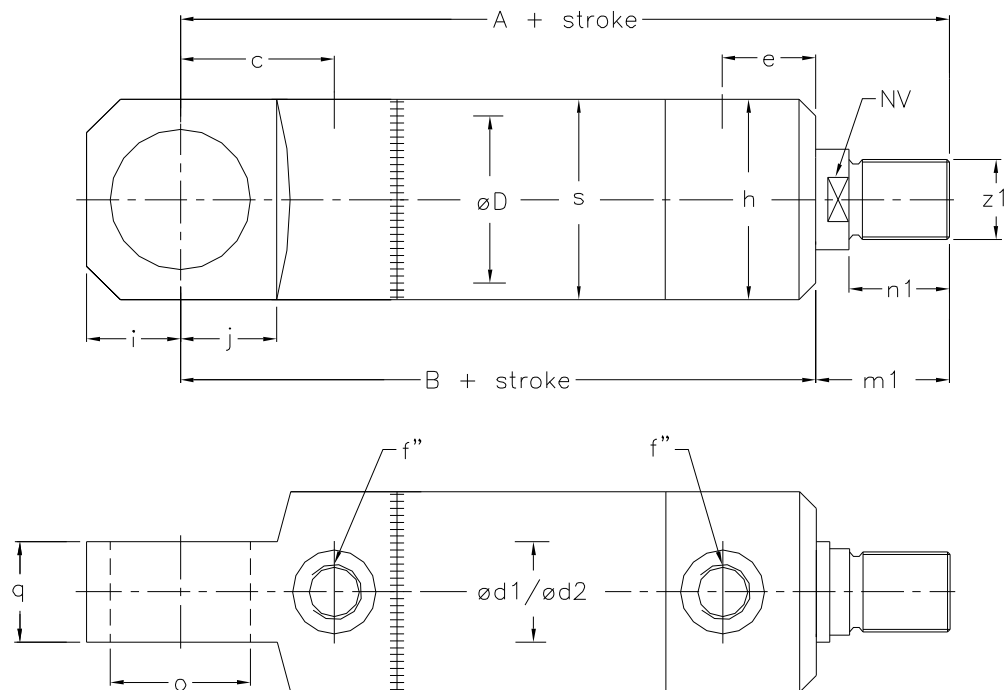

Dimension table

øD	25	32	40	50	63	80
ød1/ød2	12/16	16	20/25	25/30	30/40	40/50
A	135	155	185	217	225	265
B	95	126	150	177	180	213
c	20	24	36	46	38	50
e	26	24	25	28	28	39
f''	1/8"	1/4"	1/4"	3/8"	3/8"	1/2"
h	40	50	50/55	60	75	100
i	12	18	25	28	35	40
j	13	18	23	29	35	38
m1	40	29	35	40	45	60
n1	24	22	25	30	35	40
NV	10	13	17/22	22/27	27/36	42
o	15	26	35	42	47	62
q	15	20	25	30	35	45
s	30	40	50	60	75	95
z1	M10x1,50 M12x1,75	M12x1,75	M16x2,00 M22x2,00	M22x2,00 M24x1,50	M24x1,50 M36x2,00	M36x2,00

How to order:



SR20 VD x1 / x2 * x3 K

x1: Inside diameter : 50 mm
 x2: Piston rod : 30 mm
 x3: Stroke : 200 mm

Ordering code: SR20 VD 50/30*200 K

Eksempel på ordre:



SR20 VD x1 / x2 * x3 K

x1: Indvendig diameter : 50 mm
 x2: Stempelstang : 30 mm
 x3: Slaglængde : 200 mm

Ordre kode: SR20 VD 50/30*200 K

SR20 VD cylinders

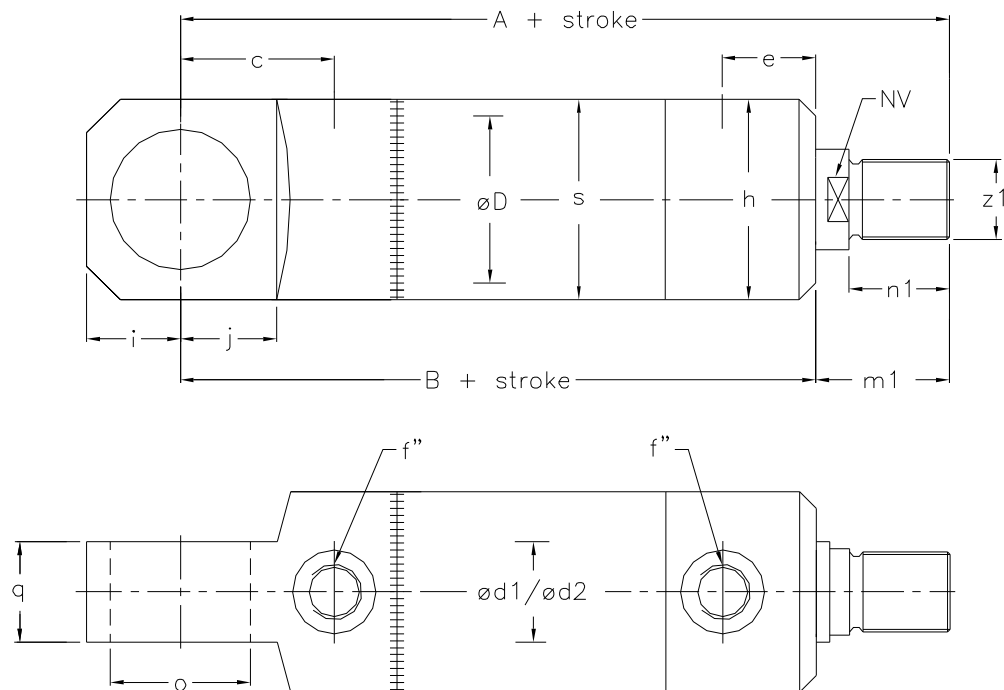

Dimension table

øD	25	32	40	50	63	80
ød1/ød2	12/16	16	20/25	25/30	30/40	40/50
A	135	155	185	217	225	265
B	95	126	150	177	180	213
c	20	24	36	46	38	50
e	26	24	25	28	28	39
f''	1/8"	1/4"	1/4"	3/8"	3/8"	1/2"
h	40	50	50/55	60	75	100
i	12	18	25	28	35	40
j	13	18	23	29	35	38
m1	40	29	35	40	45	60
n1	24	22	25	30	35	40
NV	10	13	17/22	22/27	27/36	42
o	15	26	35	42	47	62
q	15	20	25	30	35	45
s	30	40	50	60	75	95
z1	M10x1,50 M12x1,75	M12x1,75	M16x2,00 M22x2,00	M22x2,00 M24x1,50	M24x1,50 M36x2,00	M36x2,00

How to order:



SR20 VD x1 / x2 * x3 K

x1: Inside diameter : 50 mm
 x2: Piston rod : 30 mm
 x3: Stroke : 200 mm

Ordering code: SR20 VD 50/30*200 K

Eksempel på ordre:



SR20 VD x1 / x2 * x3 K

x1: Indvendig diameter : 50 mm
 x2: Stempelstang : 30 mm
 x3: Slaglængde : 200 mm

Ordre kode: SR20 VD 50/30*200 K

SR20 BL cylinders

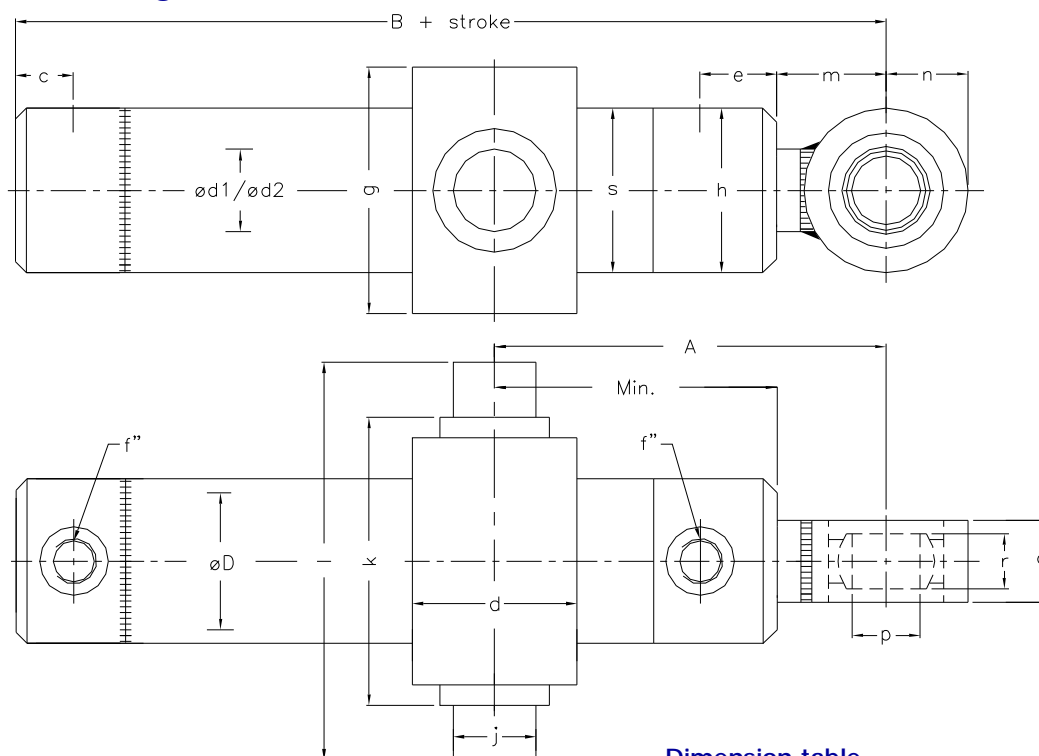

Dimension table

øD	32	40	50	63
ød1/ød2	16	20/25	25/30	30/40
B	147	163	193	209
Min.	85	90	110	125
c	16	17	21	22
d	40	50	60	70
e	24	25	28	28
f"	1/4"	3/8"	3/8"	3/8"
g	50	60	90	94
h	50	50/55	60	75
j	20	20	30	35
k	52	70	105	105
l	92	98	145	155
m	29	35	40	45
n	19	25	30	35
p	15	20	25	30
q	20	25	30	35
r	15	16	20	22
s	40	50	60	75

How to order:

SR20 BL x1 / x2 * x3 K A = x4 

x1: Inside diameter : 50 mm
 x2: Piston rod : 30 mm
 x3: Stroke : 500 mm
 x4: A = Distance : 250 mm

Ordering code: SR20 BL 50/30*500 K
 A=250 mm

Eksempel på ordre:

SR20 BL x1 / x2 * x3 K A = x4 

x1: Indvendig diameter : 50 mm
 x2: Stempelstang : 30 mm
 x3: Slaglængde : 500 mm
 x4: A = Distance : 250 mm

Ordre kode: SR20 BL 50/30*500 K
 A=250 mm